

7th International Conference on Advanced
Technology and Particle Physics

The hybrid photon detectors for the LHCb-RICH counters

Maria Girone, CERN and Imperial College

on behalf of the LHCb-RICH group

Outline of the talk

- **The LHCb-RICH system requirements** (S. Eisenhardt talk)
- **The pixel hybrid photon detector**
 - Design principle
 - Phosphor-screen prototype
 - Performance in magnetic fields
 - 61-pixel HPD prototype
 - Beam tests results (recall)
 - Towards the final HPD prototype
 - ALICE/LHCb read-out chip
 - Tests and measurements of the anodes
- **Conclusions and perspectives**

The LHCb detector

Particle identification required over
1-150 GeV/c momentum range,
and in the full angular acceptance,
10-300 mrad

RICH1: aerogel and C_4F_{10}

RICH2: CF_4

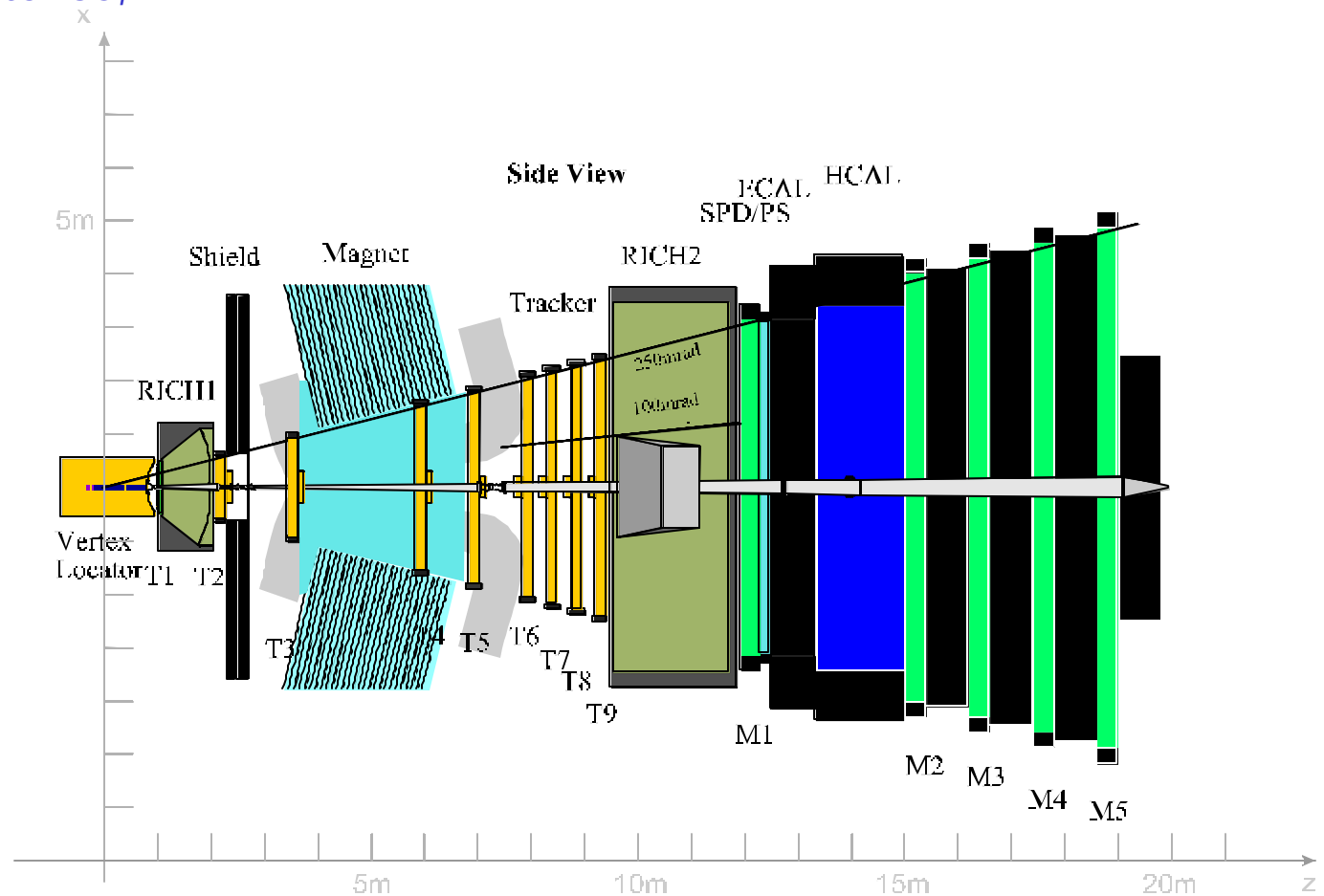

The LHCb RICH counters

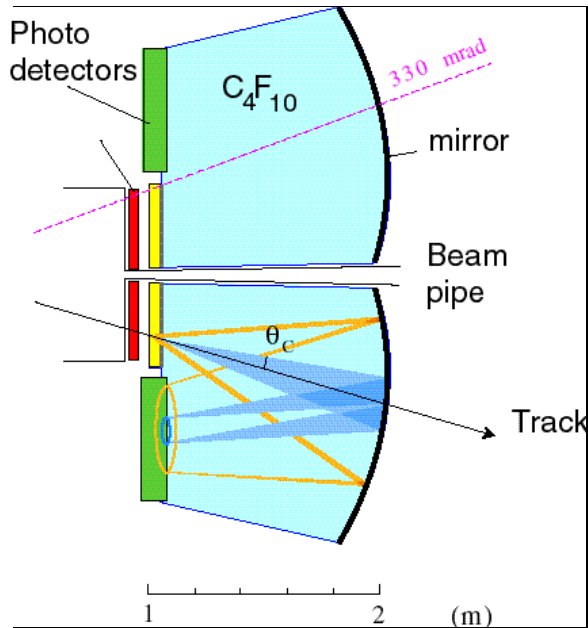

RICH1

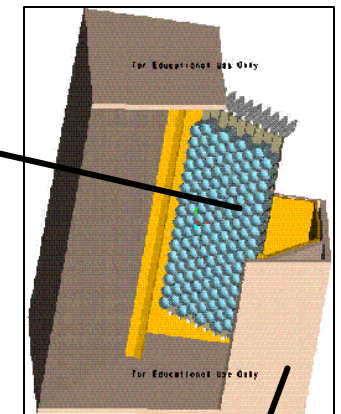
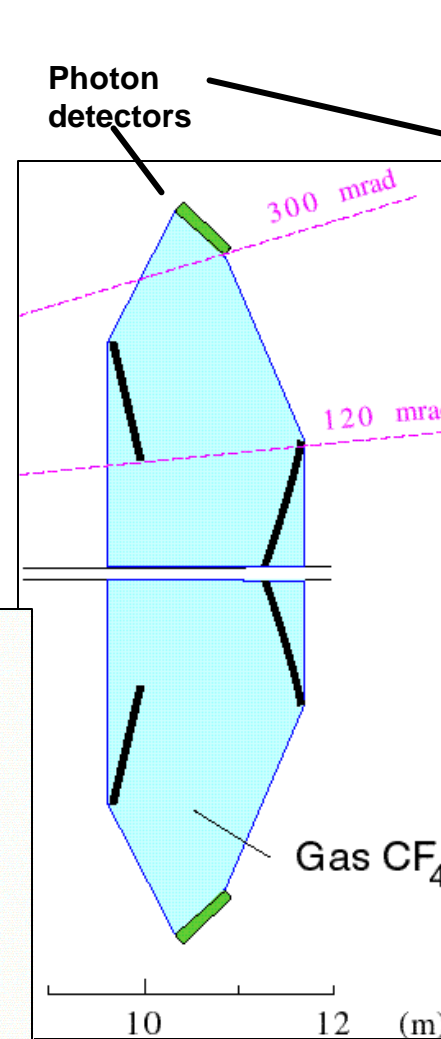

Overall magnetic shield

RICH2

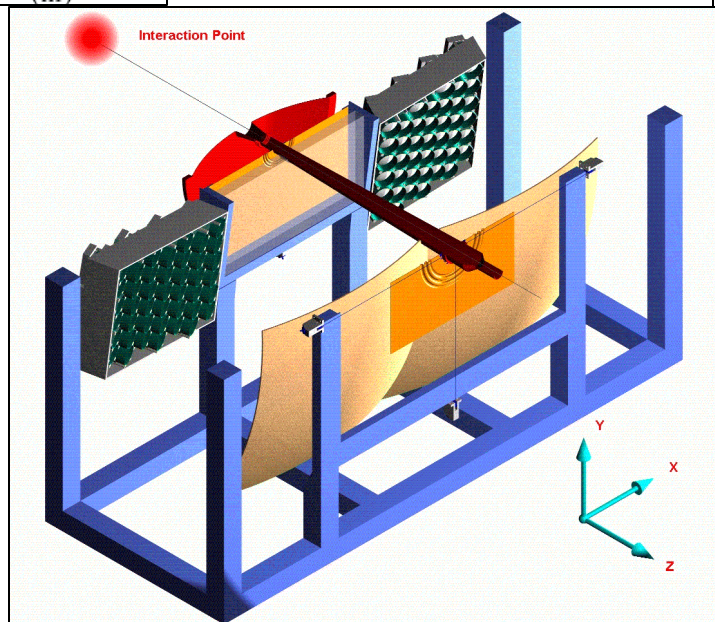

The LHCb RICH system requirements

- **Photon detection**
 - 2.6 m² total surface
 - Granularity: 2.5 × 2.5 mm²
 - Single-photon sensitivity, Cherenkov photons with $\lambda=200-600$ nm
- **Environment**
 - Magnetic stray field: ≤ 30 gauss for RICH1
 ≤ 150 gauss for RICH2 (without overall shield)
Dipole field flipping
- **Read-out**
 - Time resolution better than 25 ns, for 40MHz BC
 - Single event occupancy: ≤ 10 %
 - High LO-trigger rate (1 MHz), 4 μ s latency
- **Photo-detectors**
 - **Pixel-HPDs:** baseline solution
binary readout
 - **Multi-anode PMTs:** backup solution
analogue readout

A schematic of the HPD

Main features:

- Quartz window with a multi-alkali S20 pK
- Cross-focussing optics (tetrode structure):
 - De-magnification by ~ 5
 - $50 \mu\text{m}$ PSF ($\sim 250 \mu\text{m}$ at window level)
 - Active diameter of 75 mm (81.7 % tube coverage)
 - $\Rightarrow \sim 450$ tubes for overall RI CH system
 - 20 kV operating voltage and sensitivity to single photo-electrons $\sim 5000 e^-$ [eq. Si]
- $1024 (32 \times 32)$ pixel sensor array, $500 \mu\text{m} \times 500 \mu\text{m}$ each

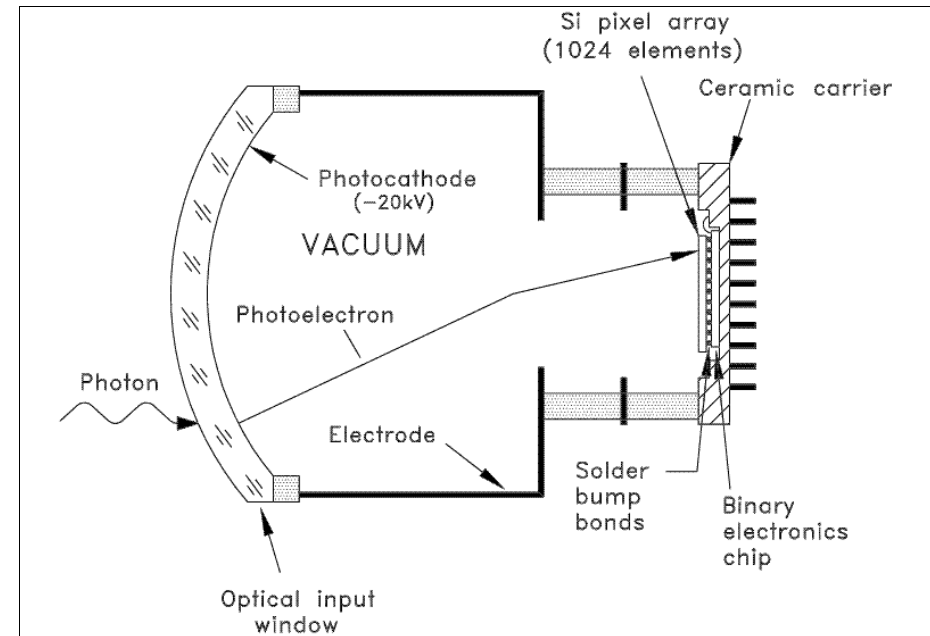

- Detector array bump-bonded to a readout chip ($0.25 \mu\text{m}$ CMOS)
- This assembly is mounted and wire-bonded onto a ceramic carrier

Phosphor screen prototype



- Prototype equipped with a phosphor screen anode read out externally with a CCD camera
- CCD chip pixel size corresponds to a resolution of $\sim 150\mu\text{m}$ at the photo-cathode, a precision beyond the required granularity of 2.5mm

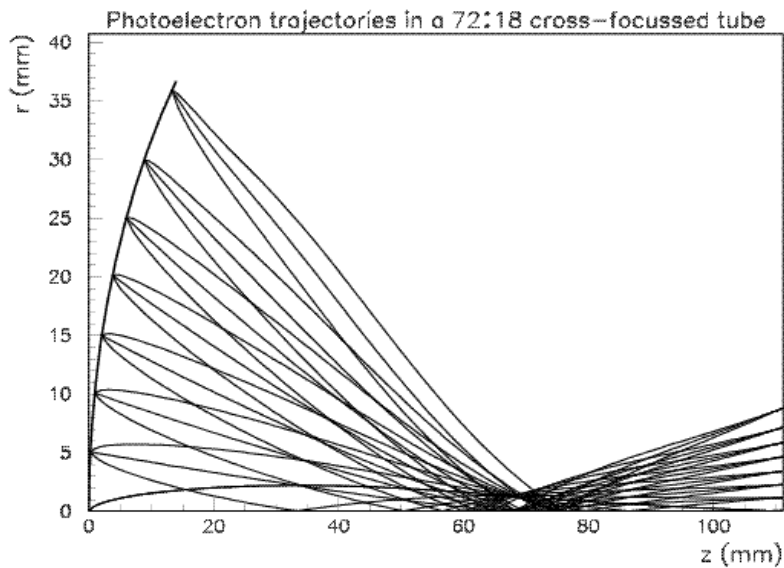

- Used to demonstrate that the electron optics meet all requirements and for studying the effects of stray magnetic fields

(M. Alemi et al., IEEE TNS 46, 6, (1999) 1901)

Sensitivity to stray magnetic field

Bare tube (i.e. without any additional shielding)

- Distortions to the optics are tolerable for fields up to 10 gauss, both axial and transverse
- Beyond 10 gauss, the mapping from anode to cathode is no longer unique

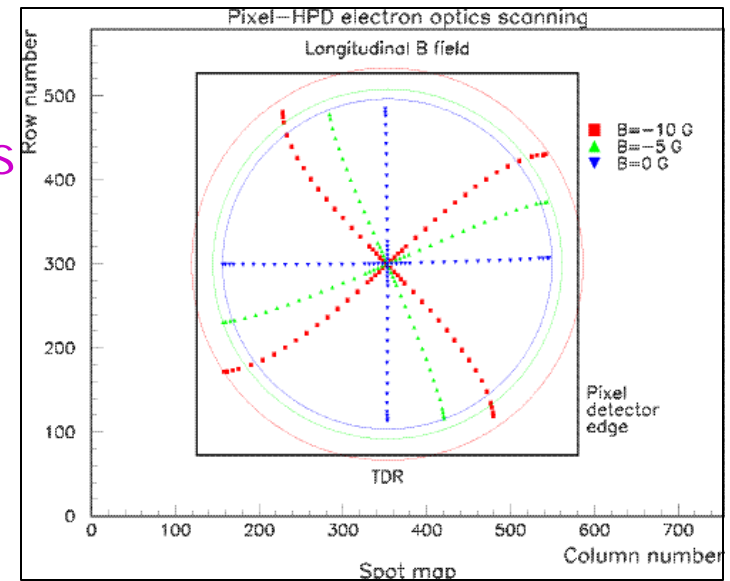

Axial field: rotation and stretching

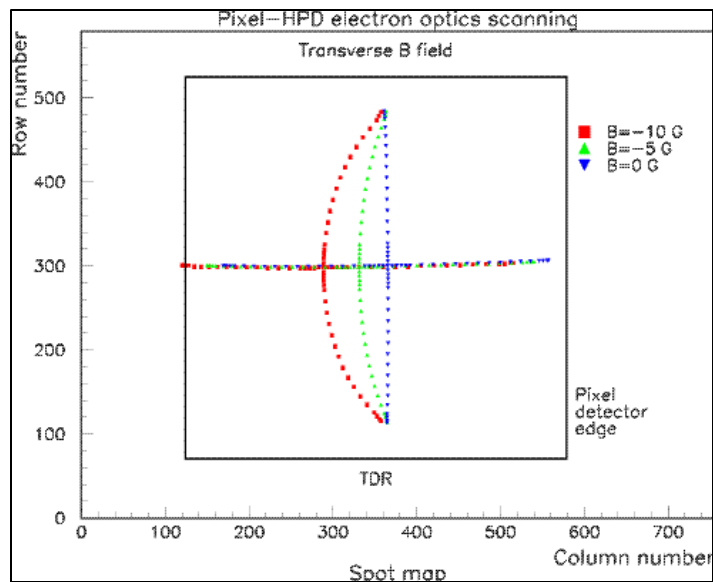

Transverse field: effect of non uniform shift

- Tube behaviour under B field flipping cycles also checked: position residuals are of the order of a few μm on the anode

61-pixel HPD prototype

Beam tests with three HPDs (recall)

- Functionality of HPDs with large pixel (2mm flat-to-flat) sensors and external analogue readout established
- Photon yields meet LHCb requirements
- Typical QE at 270nm ~23%

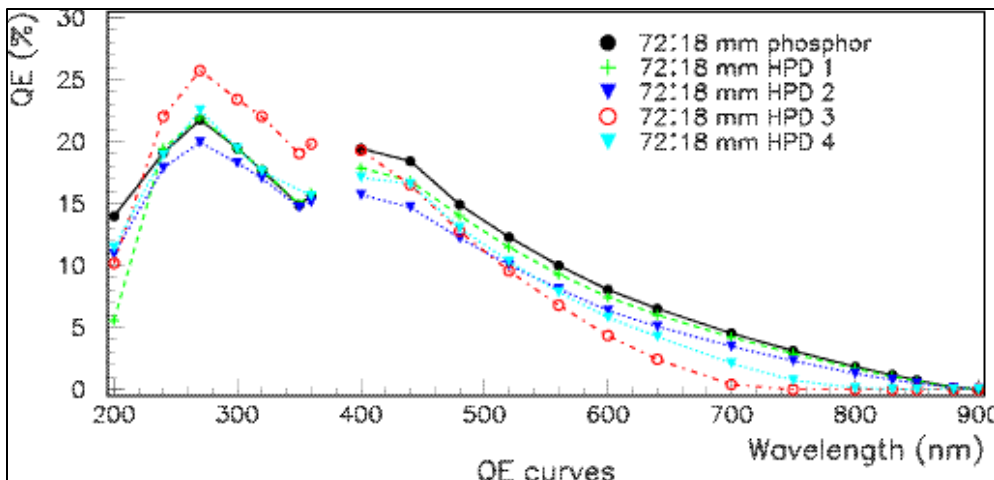
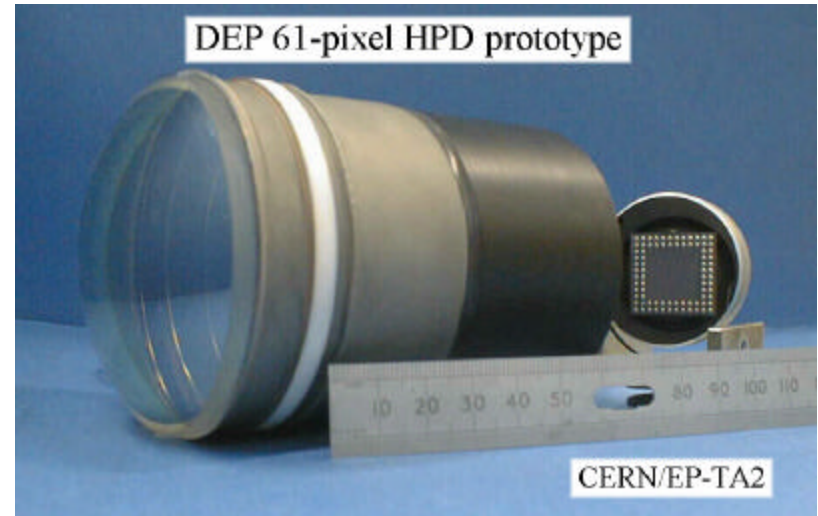

- Accumulated data set of Cherenkov rings produced by 120 GeV/c pions traversing a C_4F_{10} gas radiator
- ~35 photoelectrons/ring - raw data

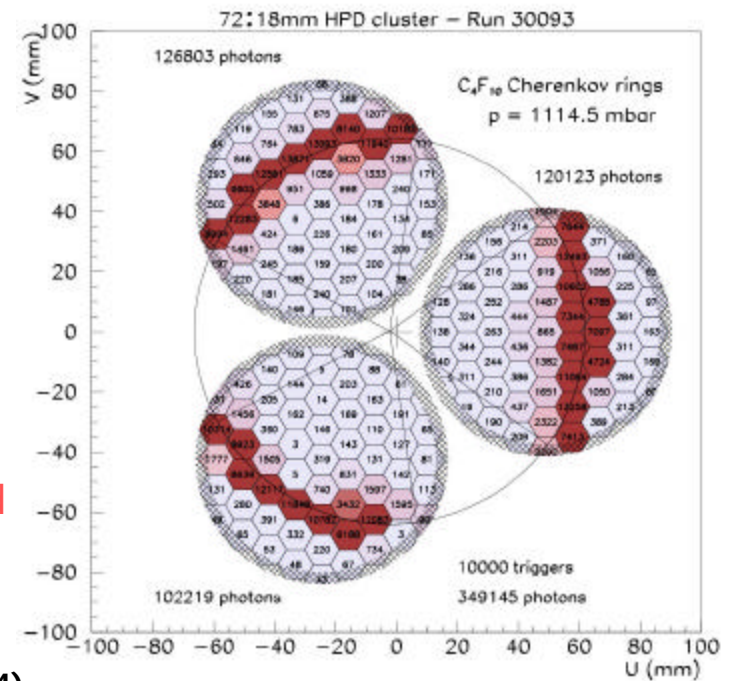

(E. Albrecht et al., NIM A 442 (2000) 164)

(T. Gys, NIM A 465 (2001) 240)

Maria Girone

9

Front-end binary pixel chip

- Joint ALICE/LHCb project for a mixed-mode integrated circuit to read out silicon pixel detectors for
 - Particle tracking in the ALICE Inner Tracking System
 - Particle identification in the LHCb RICH detector. Encapsulated pixel sensor and readout chip within a vacuum tube for the Hybrid Photon Detectors
- ALICE requirements (already met):
 - 256 x 32 pixel cells, 50 μ m x 425 μ m each
 - 10 MHz clock system
- LHCb requirements (re-optimization in progress):
 - 256 x 32 pixel cells, 62.5 μ m x 500 μ m each
 - Grouped by 8 cells, so: 32 x 32 super pixels, 500 μ m x 500 μ m
 - 40 MHz clock system

Schematic of the pixel chip

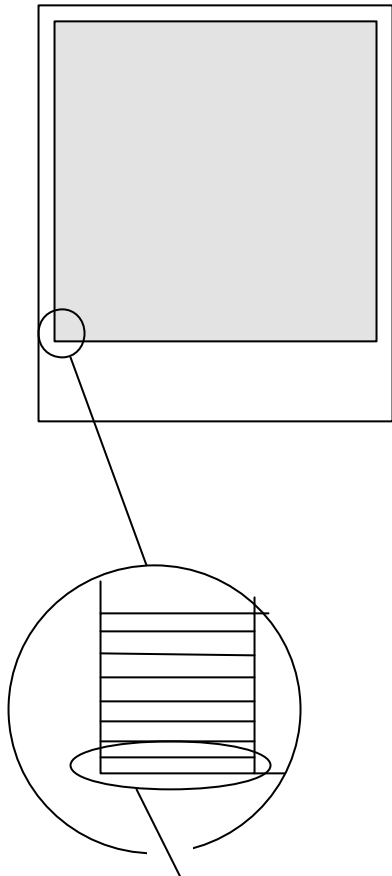

- 32x32 super-pixel array, for 16mm × 16mm active area
- Super-pixel: 500μm x 500μm , 8 pixels are ORed together, 500μm x 62.5μm each
- The pixel cell is divided into an analogue and a digital part
- A discriminator compares the output of the shaper with a threshold fixed globally. Each pixel contains three logic bits to finely adjust the thresholds on a pixel-to-pixel basis

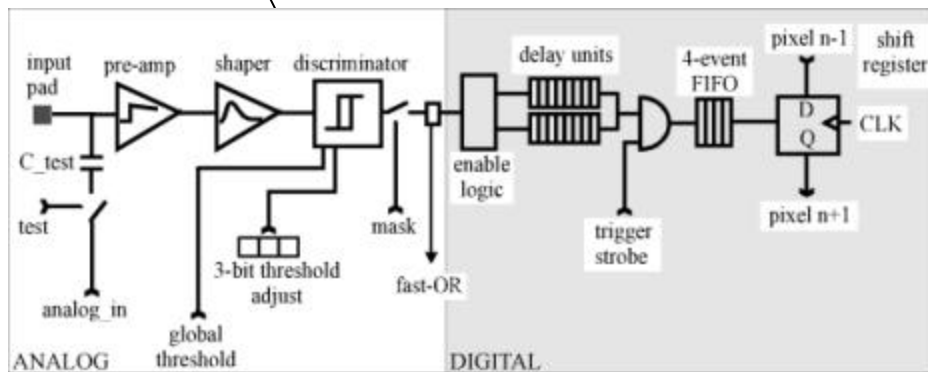

Baseline requirements:

- threshold < 2000e⁻, noise < 250e⁻
- 25ns time resolution
- 40 MHz readout

The assemblies

- The first LHCb sensors have been bump-bonded to the present ALICE/LHCb chip (13.6mmx12.8mm)
- They have been mounted and wire-bonded onto a custom made ceramic carrier
- After tests, they are encapsulated into the phototube

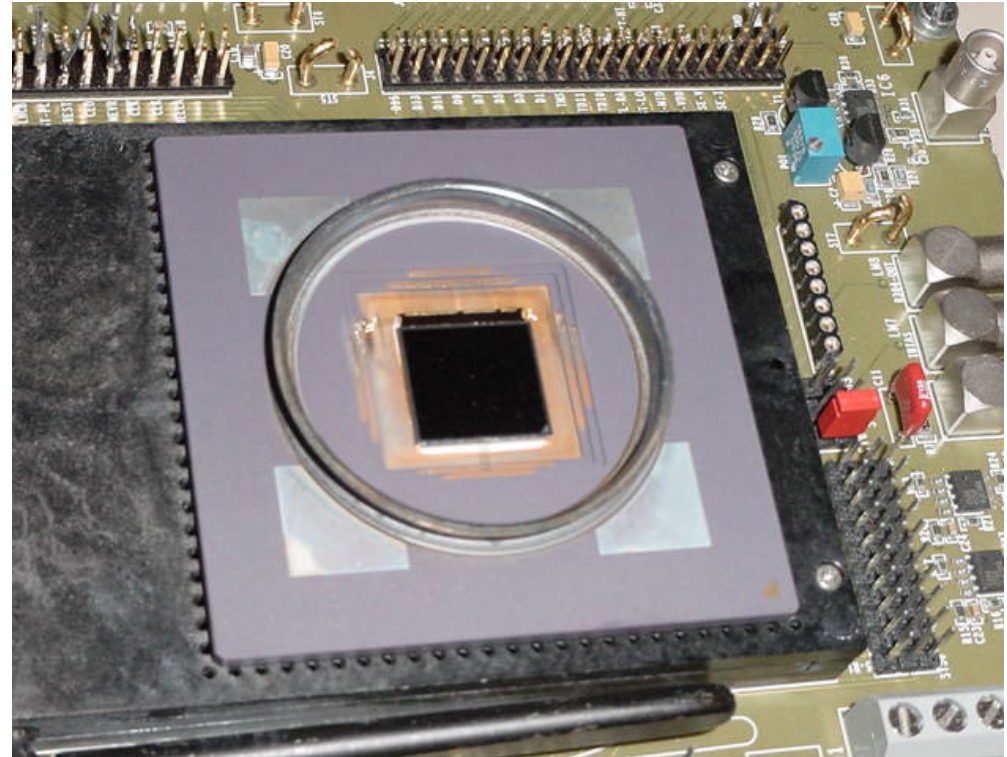

Tests of the assemblies

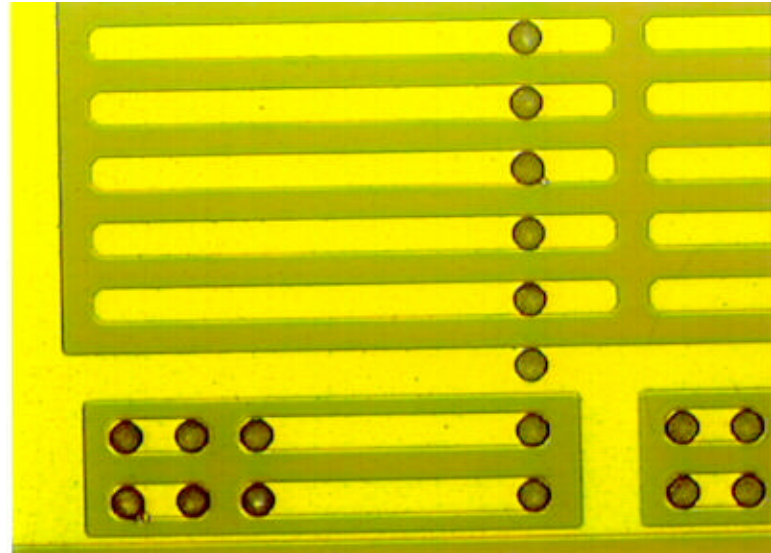

- Good bump-bonding
- Eight assemblies available for tests
 - Electronics chip tests. Expected yield for 0.25 μ m CMOS technology is ~35%
 - Detector I-V curve measurements
 - Electrical calibration of noise and minimum threshold
 - Source measurements (Fe^{55} , Cd^{109} , Sr^{90})

Chip Lab Tests

- Stable operational settings
- Threshold scans measurements:

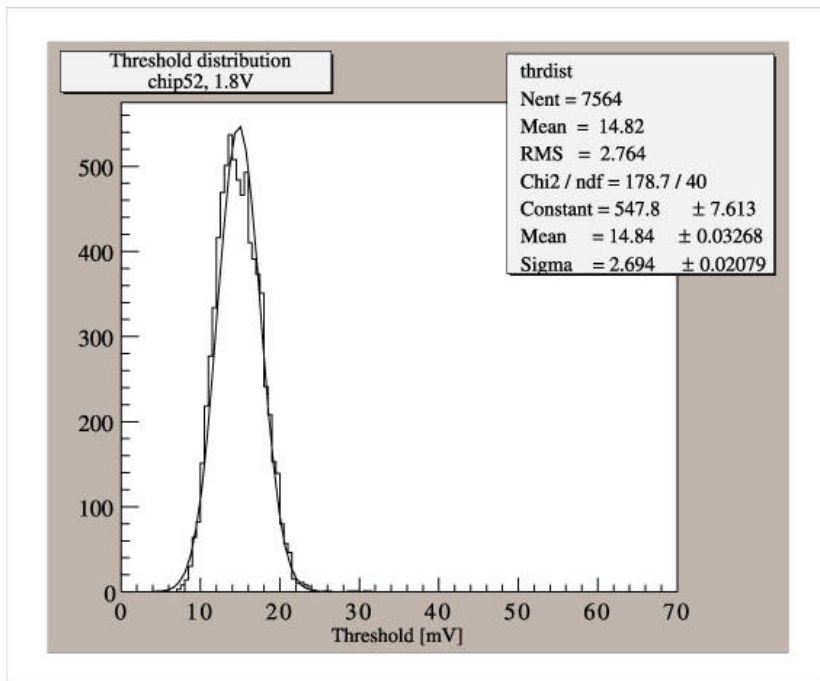

Minimum average threshold
~700e⁻ (RMS ~150e⁻ without 3-bit adjust)

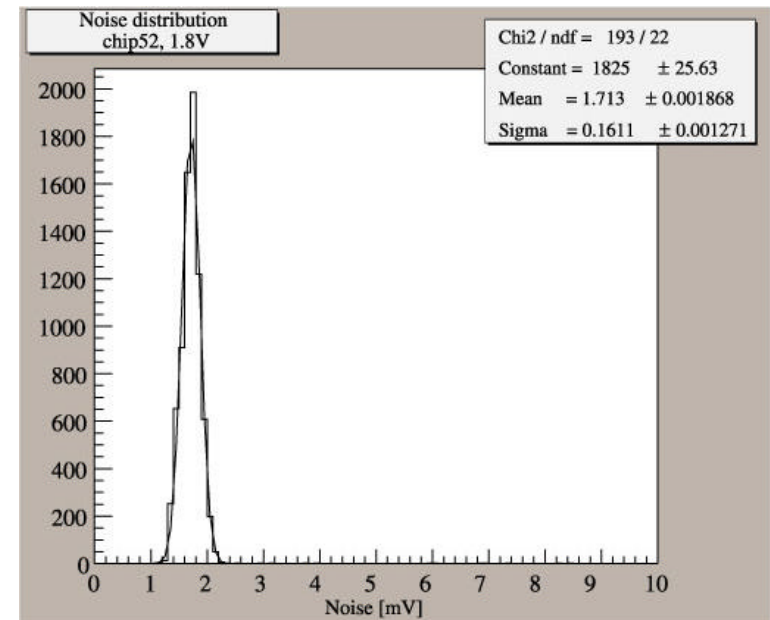

Average noise ~90 e⁻
(RMS ~8e⁻)

Thresholds scans

- Minimum threshold $\sim 700e^-$ (LHCb requirement: 2000 e^-)
- Noise $\sim 90 e^-$ (LHCb requirement: 250 e^-)

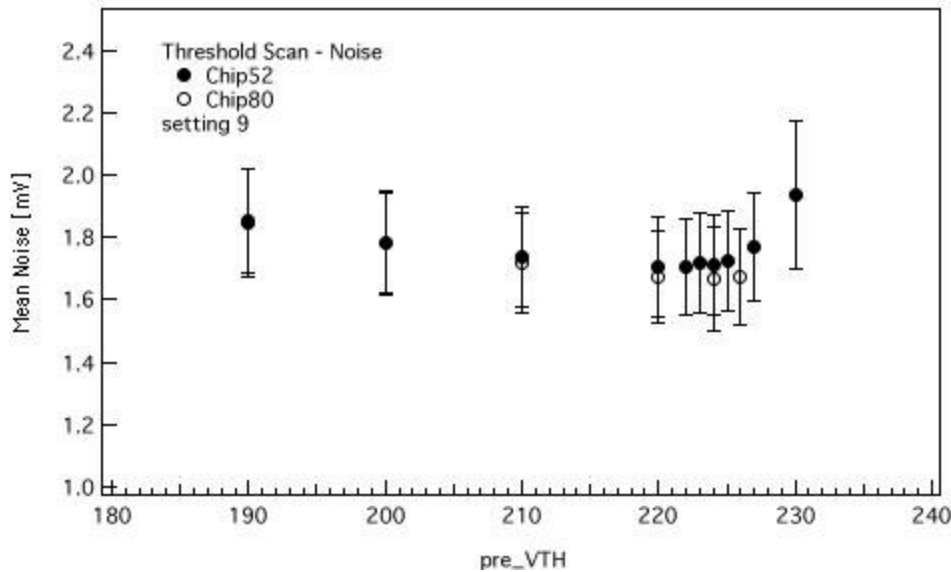

← Higher thresholds

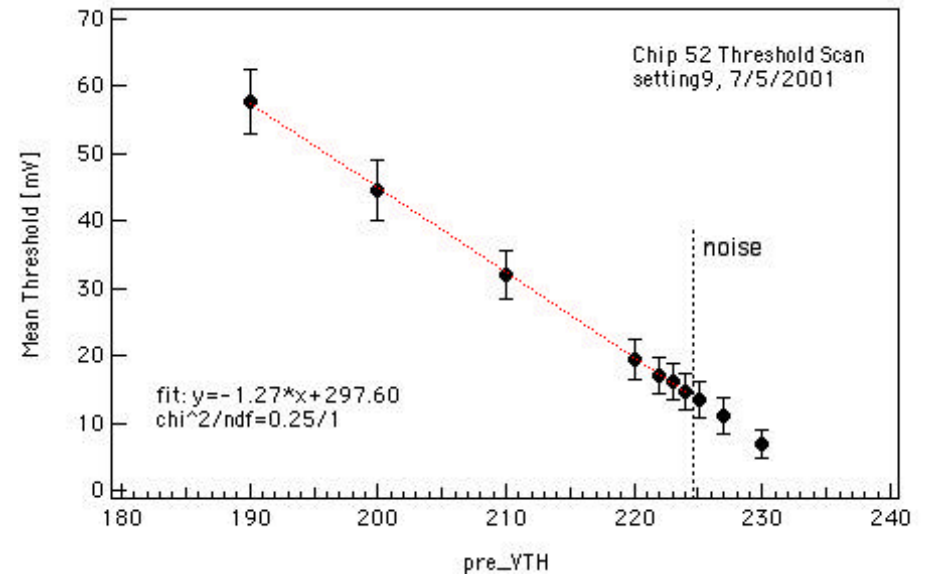

Courtesy of P. Riedler/ALICE-pixel group

Minimum threshold $\sim 700e^-$ for bare chip

Minimum threshold $\sim 1150e^-$ for bump-bonded assembly

First results from the LHCb assemblies

- Three operational electronics chips (expected yield)
- Satisfactory leakage currents (~ 100 nA at 80V, on $\sim 1.7\text{cm}^2$)
- Sensitive to Fe^{55} ($5.9\text{keV} \sim 1600 e^-$) i.e. better than required sensitivity to single photoelectrons ($20\text{keV} \sim 5000 e^-$)
- Two assemblies sent for encapsulation in the photon tube (third one has poor bump-bonding)

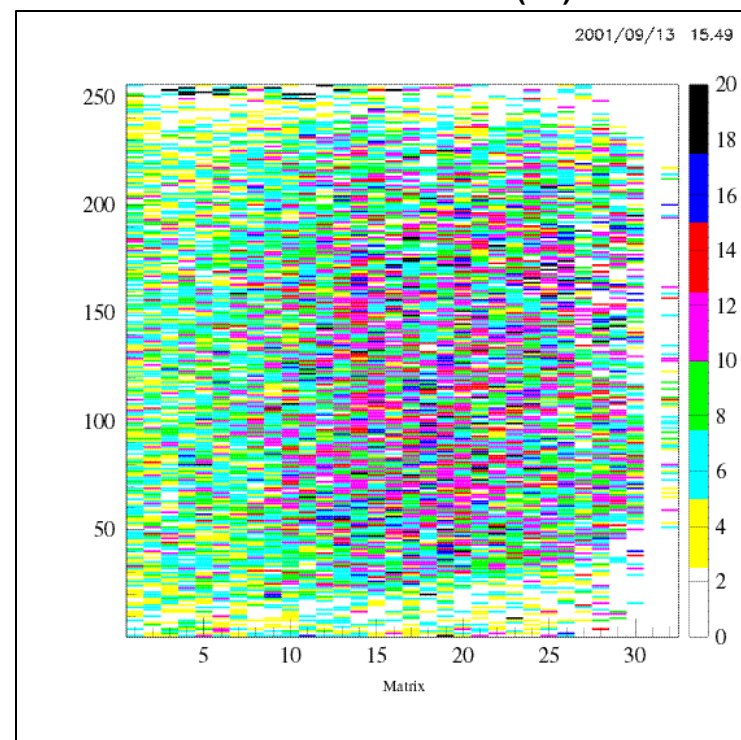
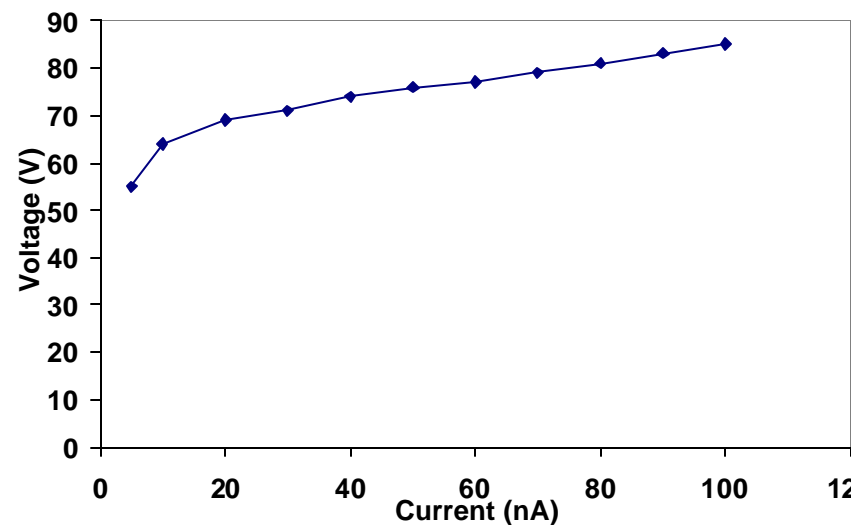

Conclusions and perspectives

- Final HPD prototype
 - Current development involves encapsulation of the 1024 pixel anode, bump-bonded to the ALICE/LHCb chip (0,25 μ m CMOS)
- Status of the pixel sensors
 - ALICE/LHCb chip functional
 - Good bump bonding
 - Noise and minimum threshold significantly better than requirements
 - Source measurements performed
 - Re-optimization of the readout chip in progress for matching LHCb requirements. Chip submission imminent
- First 1024-pixel HPD prototype expected by end of 2001

Conclusions and perspectives

- Status of the LHCb-RI CH pixel HPD existing prototypes
 - Phosphor anode HPD, read-out using a CCD camera
 - The electron optics requirements have been fulfilled
 - Detailed magnetic field tests show that up to 10G stray field can be tolerated for a bare tube without additional Mumetal shield (and 30G for a tube with a 0.9mm Mumetal shielding)
 - 61-pixel anode HPD
 - Electronics successfully tested in the lab and in the RI CH 1 prototype in beam tests
 - Photon yields meet the LHCb requirements

Magnetic shielding requirements

Phosphor screen HPD prototype shielded by a 0.9mm thick Mu-metal cylinder

- Up to 30 Gauss stray field can be tolerated
 - Image confined within sensitive area
 - Image distortions to be corrected offline
 - Unique cathode-anode mapping

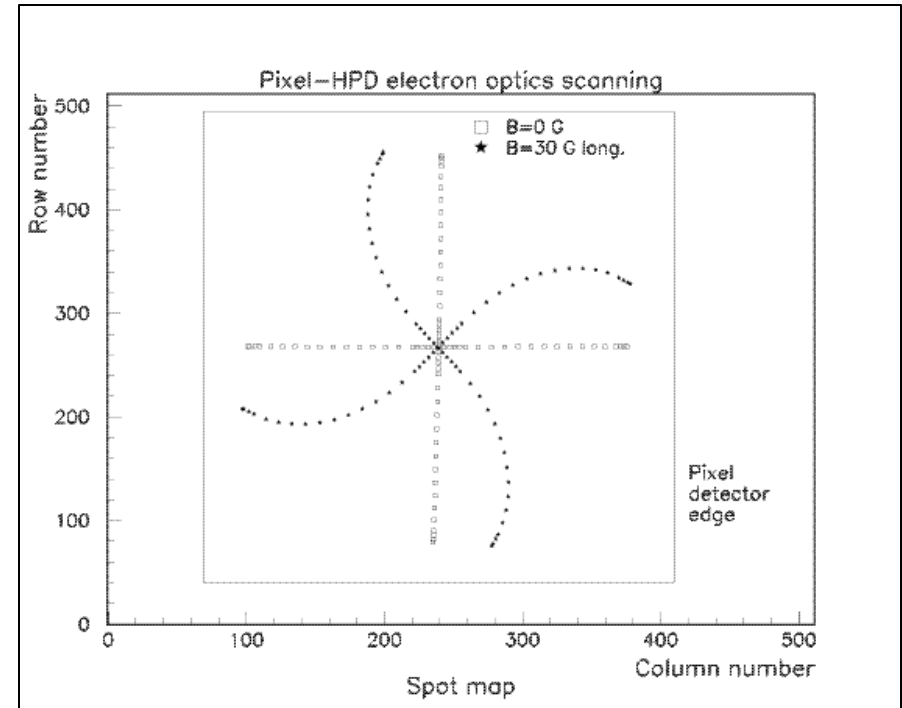
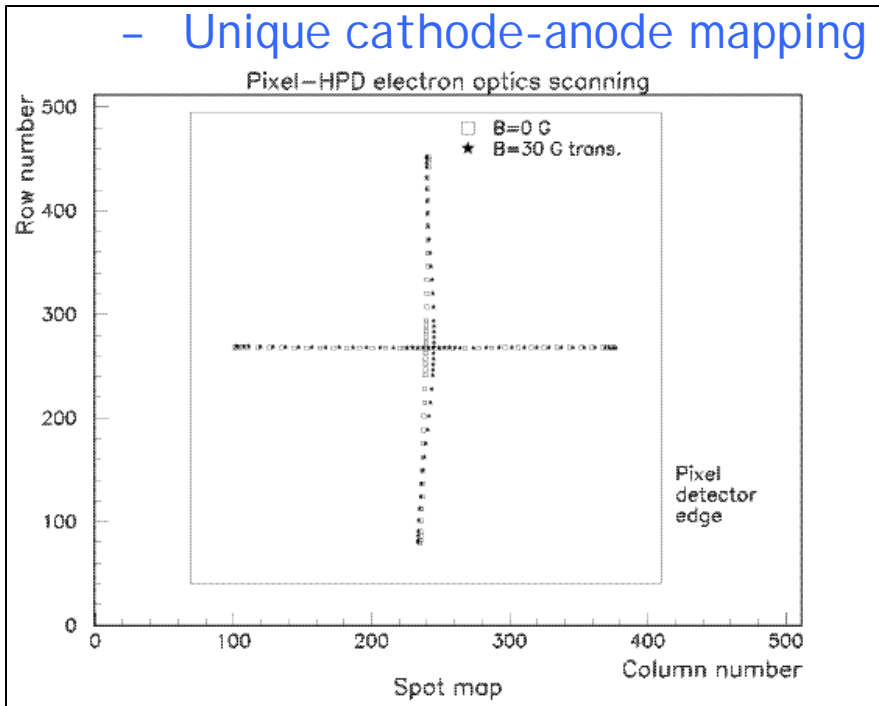

Axial field: rotation and stretching

Transverse field: effect of non uniform shift